

Uplink Sum-Rate Analysis of C-RAN With Interconnected Radio Units

Seok-Hwan Park¹, Osvaldo Simeone² and Shlomo Shamai (Shitz)³

¹Division of Electronic Engineering, Chonbuk National University, Jeonju, 54896 Korea

²Centre for Telecommunications Research, Department of Informatics, King's College London, London WC2R 2LS, UK

³Department of Electrical Engineering, Technion, Haifa, 32000, Israel

Email: seokhwan@jbnu.ac.kr, osvaldo.simeone@njit.edu, sshlomo@ee.technion.ac.il

Abstract—This study addresses the achievable sum-rate for the uplink of a cloud radio access network (C-RAN) operating in a linear Wyner-type topology, i.e., with partial channel connectivity. In the system, the radio units (RUs) communicate with a central, or cloud, unit (CU) by means of digital finite-capacity fronthaul links. The messages sent by the user equipments (UEs) are jointly decoded by the CU based on the compressed baseband signals received on the fronthaul links. Unlike prior works, each RU is assumed to be also connected to its neighboring RUs via finite-capacity fronthaul links. Under the standard assumption that the RUs do not perform channel decoding (i.e., oblivious RUs), each RU performs in-network processing of the uplink received signal and of the compressed baseband signal received from the adjacent RU, with the CU carrying out channel decoding. A closed-form expression of the achievable sum-rate is derived assuming point-to-point compression, and then analytical expressions are provided for more advanced fronthaul compression schemes that leverage side information. Numerical examples provide insights into the advantages of inter-RU communications and into the performance gap to existing sum-rate upper bounds.

Index Terms—C-RAN, connected RUs, oblivious processing, fronthaul compression.

I. INTRODUCTION

Cloud radio access network (C-RAN) is an established architecture for 5G systems, in which the baseband signal processing functionalities, which are currently performed at the base stations (BSs) in LTE deployments, are migrated to a baseband processing unit (BBU) pool located within a cloud unit (CU) [1]. Since the BSs in C-RAN merely retain radio functionalities, they are also referred to as radio units (RUs).

One of the main challenges in implementing C-RAN systems is that the fronthaul links that connect the RUs to the CU have finite capacities [1]. For the uplink, the typical solution is for the RUs to quantize the received baseband signals before sending them to the CU on a digital fronthaul link. With the aim of improving over standard quantization methods, advanced fronthaul compression techniques inspired by network information theory were proposed in [2]–[7]. Specifically,

S.-H. Park was supported by the NRF Korea funded by the Ministry of Science, ICT & Future Planning through grant 2015R1C1A1A01051825. The work of O. Simeone was partially supported by the U.S. NSF through grant CCF-1525629. O. Simeone has also received funding from the European Research Council (ERC) under the European Union's Horizon 2020 research and innovation programme (grant agreement No 725731). The work of S. Shamai has been supported by the European Union's Horizon 2020 Research And Innovation Programme, grant agreement no. 694630.

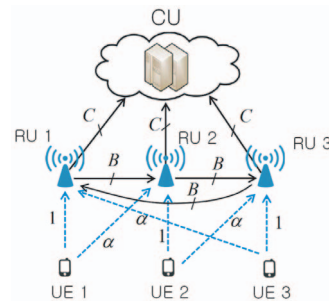

Figure 1. Illustration of the uplink of a Wyner-type C-RAN system with inter-connected RUs ($N = 3$).

in [2]–[7], distributed compression techniques were studied, whereby the CU leverages the statistical correlation of the received signals across nearby RUs. The works [3] and [5] investigated methods based on successive decompression and channel decoding, while the papers [2], [4] and [7] analyzed the performance gains that are achieved via joint decompression and decoding.

This work is motivated by the observation that 5G deployments may enable not only RU-to-CU fronthaul connections, but also inter-RU fronthaul links [8]. In light of this, we examine the potential advantages of inter-RU cooperation as enabled by inter-RU fronthaul links in terms of achievable uplink sum-rate performance.

The impact of inter-RU cooperation was analyzed in [9][10] for non-cooperative cellular systems under Wyner and circular Wyner models, i.e., with partial channel connectivity. Instead, in [11], the authors studied the impact of inter-user equipments (UEs) and inter-RU cooperation on the uplink per-UE multiplexing gain under Wyner's soft-handoff model.

In this work, we consider a C-RAN operating in a linear Wyner-type topology with partial channel connectivity and inter-RU finite-capacity fronthaul links. Under the standard assumption that the RUs do not perform channel decoding, i.e., oblivious RUs, each RU performs in-network processing of the uplink received signal and of the compressed baseband signal received from the adjacent RU, with the CU carrying out channel decoding. We derive a closed-form expression of the achievable sum-rate with point-to-point (P2P) compression, and provide analytical expressions for more advanced

fronthaul compression schemes that leverage side information (SI). Numerical examples are provided to gain insights into the advantages of inter-RU communications and into the performance gap to existing sum-rate upper bounds.

The rest of the paper is organized as follows. In Sec. II, we present the system model and the operation at the UEs, RUs and the CU. We derive the maximum achievable sum-rate for the P2P compression in Sec. IV, and the advantages of leveraging SI and of jointly performing decompression and decoding tasks are discussed in Sec. V and Sec. VI, respectively. Numerical examples are presented in Sec. VII, and we close the paper with concluding remarks in Sec. VIII.

II. SYSTEM MODEL

We consider the uplink of a C-RAN under a Wyner-type Gaussian soft-handoff model illustrated in Fig. 1 (see, e.g., [10, Sec. 2.1]). Accordingly, there are N pairs of RUs and UEs, and each RU $i \in \mathcal{N} \triangleq \{1, \dots, N\}$ receives the signal

$$Y_i = X_i + \alpha X_{[i-1]} + Z_i, \quad (1)$$

where X_i represents the transmit signal of UE i ; $\alpha \in [0, 1]$ denotes the inter-cell channel gain; and $Z_i \sim \mathcal{N}(0, \sigma^2)$ is the additive noise. The modulo operation $[A]$ outputs $A + nN$ for integer n such that the output lies in $1 \leq [A] \leq N$.

As in standard C-RAN systems, we assume oblivious processing at the RUs in the sense that decoding of the messages $\mathbf{M} \triangleq \{M_i\}_{i \in \mathcal{N}}$ is only performed at the CU and not at the RUs. The CU is connected to the RUs via orthogonal fronthaul links each of capacity C bit/symbol. Unlike existing works on C-RAN for the Wyner model [3][6], we assume that each RU i has a fronthaul link of capacity B bit/symbol connecting it to the nearby RU $[i+1]$ so as to enable inter-RU cooperation. Note that the same model was also studied in [9][10] but in the absence of RU-to-CU fronthaul links.

Each UE i encodes a message $M_i \in \{1, \dots, 2^{nR_i}\}$ to obtain an encoded signal $X_i \sim \mathcal{N}(0, P)$ using standard random coding. The signal-to-noise ratio (SNR) of the uplink channel is defined as $\text{SNR} = P/\sigma^2$, and the rate of the message M_i is R_i . The coding block length n is assumed to be sufficiently large to justify the use of information-theoretic arguments.

III. OBLIVIOUS IN-NETWORK PROCESSING VIA INTER-RU LINKS

In this section, we describe the proposed operation of the system under oblivious processing at the RUs. As shown in Fig. 2, the RU i does not decode the message M_i but instead produces two quantized signals $\hat{Y}_{C,i}$ and $\hat{Y}_{B,i}$ to be delivered to the CU and RU $[i+1]$, respectively. Note that in conventional C-RAN systems, only the signal $\hat{Y}_{C,i}$ is produced by each RU i .

To elaborate, RU i quantizes its received signal Y_i to obtain the signal $\hat{Y}_{B,i}$ which is given as

$$\hat{Y}_{B,i} = Y_i + Q_{B,i} \quad (2)$$

with the quantization noise $Q_{B,i} \sim \mathcal{N}(0, \omega_{B,i})$ using standard random coding and joint typicality compression. The quantized signal $\hat{Y}_{B,i}$ is transferred to RU $[i+1]$ over the inter-RU link.

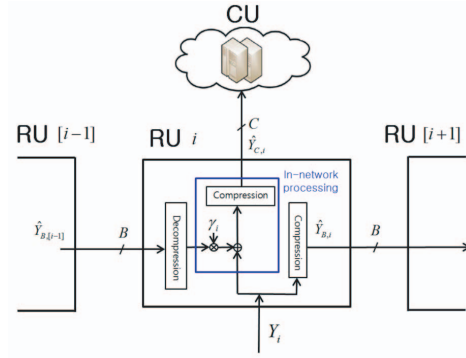

Figure 2. Illustration of the relaying operation at RU i .

The quantized signal $\hat{Y}_{C,i}$ is obtained by performing linear *in-network processing* of the signals Y_i and $\hat{Y}_{B,[i-1]}$ received on the uplink channel and from the adjacent RU $[i-1]$. Accordingly, it is written as

$$\hat{Y}_{C,i} = S_i + Q_{C,i}, \quad (3)$$

where we defined the linearly combined output signal S_i as

$$S_i = \gamma_i \hat{Y}_{B,[i-1]} + Y_i, \quad (4)$$

and the quantization noise $Q_{C,i}$ is distributed as $Q_{C,i} \sim \mathcal{N}(0, \omega_{C,i})$.

The relationship between the variables $\omega_{B,i}$, $\omega_{C,i}$ and γ_i and the fronthaul capacities C and B for different compression strategies will be detailed in Sec. IV and Sec. V. Unless stated otherwise, by symmetry, we assume that the variables $\omega_{B,i}$, $\omega_{C,i}$ and γ_i are the same for all RUs i , i.e., $\omega_{B,i} = \omega_B$, $\omega_{C,i} = \omega_C$ and $\gamma_i = \gamma$ for all $i \in \mathcal{N}$.

The vector $\hat{\mathbf{Y}}_C = [\hat{Y}_{C,1} \dots \hat{Y}_{C,N}]^T$ obtained by stacking all the decompressed signals at the CU can be written as

$$\hat{\mathbf{Y}}_C = \mathbf{H}_X \mathbf{X} + \mathbf{H}_Z \mathbf{Z} + \mathbf{H}_Q \mathbf{Q}_B + \mathbf{Q}_C, \quad (5)$$

where we defined the signal vectors $\mathbf{X} = [X_1 X_2 \dots X_N]^T$, $\mathbf{Z} = [Z_1 Z_2 \dots Z_N]^T$, $\mathbf{Q}_B = [Q_{B,1} Q_{B,2} \dots Q_{B,N}]^T$ and $\mathbf{Q}_C = [Q_{C,1} Q_{C,2} \dots Q_{C,N}]^T$ and the effective channel matrices $\mathbf{H}_X = \mathbf{I} + (\gamma + \alpha)\mathbf{E}_1 + \gamma\alpha\mathbf{E}_2$, $\mathbf{H}_Z = \mathbf{I} + \gamma\mathbf{E}_1$ and $\mathbf{H}_Q = \gamma\mathbf{E}_1$. Here the matrices \mathbf{E}_1 and \mathbf{E}_2 are circulant matrices with the first rows given as $[0_{1 \times (N-1)} 1]$ and $[0_{1 \times (N-2)} 1 0]$, respectively. Note that we have the properties $\mathbf{E}_1 \mathbf{E}_1^T = \mathbf{E}_2 \mathbf{E}_2^T = \mathbf{I}$, $\mathbf{E}_1 \mathbf{E}_2^T = \mathbf{E}_1^T$ and $\mathbf{E}_2 \mathbf{E}_1^T = \mathbf{E}_1$.

Under the assumption that the CU jointly decodes the messages based on the decompressed signals $\hat{\mathbf{Y}}_C$, the achievable sum-rate $R_\Sigma = \sum_{i \in \mathcal{N}} R_i$ of the UEs is given as

$$\begin{aligned} R_\Sigma &= f(\omega_B, \omega_C, \gamma) \triangleq I(\mathbf{X}; \hat{\mathbf{Y}}_C) \\ &= \frac{1}{2} \log_2 \left| \mathbf{I} + P (\sigma^2 \mathbf{H}_Z \mathbf{H}_Z^T + \omega_B \mathbf{H}_Q \mathbf{H}_Q^T + \omega_C \mathbf{I})^{-1} \mathbf{H}_X \mathbf{H}_X^T \right| \\ &= \frac{1}{2} \sum_{i \in \mathcal{N}} \log_2 \left(1 + P \frac{\left(1 + (\gamma + \alpha)^2 + \gamma^2 \alpha^2 + (\gamma + \alpha)(1 + \gamma\alpha) \lambda_{1,i} + \gamma\alpha \lambda_{2,i} \right)}{\left(\sigma^2 \gamma \lambda_{1,i} + \sigma^2 (\gamma^2 + 1) + \omega_B \gamma^2 + \omega_C \right)} \right), \end{aligned} \quad (6)$$

where we defined the eigenvalue decompositions $\mathbf{E}_k + \mathbf{E}_k^T = \mathbf{V}\mathbf{D}_k\mathbf{V}^T$, $k \in \{1, 2\}$, with the diagonal matrices $\mathbf{D}_k = \text{diag}(\lambda_{k,1}, \dots, \lambda_{k,N})$ of eigenvalues $\lambda_{k,1}, \dots, \lambda_{k,N}$ of $\mathbf{E}_k + \mathbf{E}_k^T$. The eigenvalues $\lambda_{k,l}$ can be written as

$$\lambda_{k,l} = 2 \cos \left(2k\pi \frac{l-1}{N} \right), \quad (7)$$

for $k \in \{1, 2\}$ and $l \in \mathcal{N}$.

IV. POINT-TO-POINT COMPRESSION

In this section, we discuss the selection of the quantization noise variances ω_B , ω_C and the in-network processing coefficient γ under the assumption that the RUs and the CU perform conventional P2P compression without leveraging SI.

If we assume that the RU $[i+1]$ decompresses the signals $\hat{Y}_{B,i}$ using conventional P2P compression, the quantization noise power ω_B should satisfy the condition [12, Ch. 3]

$$\begin{aligned} g_B(\omega_B) &\triangleq I(Y_i; \hat{Y}_{B,i}) \\ &= \frac{1}{2} \log_2 \left(1 + \frac{P(1 + \alpha^2) + \sigma^2}{\omega_B} \right) \leq B. \end{aligned} \quad (8)$$

In a similar manner, with conventional P2P compression, the quantization noise powers ω_B and ω_C and the in-network processing coefficient γ are subject to the constraint

$$\begin{aligned} g_C(\omega_B, \omega_C, \gamma) &\triangleq I(S_i; \hat{Y}_{C,i}) \\ &= \frac{1}{2} \log_2 \left(1 + \frac{E[S_i^2]}{\omega_C} \right) \leq C, \end{aligned} \quad (9)$$

where the variance $E[S_i^2]$ is given as

$$\begin{aligned} E[S_i^2] &= \left(\gamma^2 \alpha^2 + (\gamma + \alpha)^2 + 1 \right) P + \gamma^2 \omega_B \\ &\quad + (1 + \gamma^2) \sigma^2. \end{aligned} \quad (10)$$

The problem of finding the maximum sum-rate can be then stated as

$$\underset{\omega_B, \omega_C \geq 0, \gamma}{\text{maximize}} f(\omega_B, \omega_C, \gamma) \quad (11a)$$

$$\text{s.t. } g_B(\omega_B) \leq B, \quad (11b)$$

$$g_C(\omega_B, \omega_C, \gamma) \leq C. \quad (11c)$$

Since the sum-rate in (6) is a monotonically decreasing function of the variables ω_B and ω_C , the optimal quantization noise power variables ω_B and ω_C can be taken without loss of optimality such that the constraints (11b) and (11c) are satisfied with equality, i.e.,

$$\omega_B = \beta_B \left((1 + \alpha^2) P + \sigma^2 \right) \quad (12)$$

$$\text{and } \omega_C = \beta_C \Theta(\gamma), \quad (13)$$

with $\beta_B = 1/(2^{2B} - 1)$, $\beta_C = 1/(2^{2C} - 1)$ and $\Theta(\gamma) = (\gamma^2 \alpha^2 + (\gamma + \alpha)^2 + 1)P + \gamma^2 \omega_B + (1 + \gamma^2) \sigma^2$. The main result is summarized in the following proposition.

Proposition 1. *An achievable sum-rate R_Σ with P2P compression is given by the solution of problem (11), which can be simplified as*

$$\underset{\gamma}{\text{maximize}} \tilde{f}_{\text{P2P}}(\gamma) = \frac{1}{2} \sum_{i \in \mathcal{N}} \log_2(1 + P\Upsilon_i), \quad (14)$$

where we defined

$$\Upsilon_i = \frac{\left(\begin{array}{l} 1 + (\gamma + \alpha)^2 + \gamma^2 \alpha^2 + 2(\gamma + \alpha) \times \\ (1 + \gamma\alpha) \cos(2\pi \frac{i-1}{N}) + 2\gamma\alpha \cos(4\pi \frac{i-1}{N}) \end{array} \right)}{\left(\begin{array}{l} 2\sigma^2 \gamma \cos(2\pi \frac{i-1}{N}) + \\ \sigma^2(\gamma^2 + 1) + \omega_B \gamma^2 + \beta_C \Theta(\gamma) \end{array} \right)}. \quad (15)$$

The optimal combining coefficient γ in (14) can be found via a simple one-dimensional search.

Remark 1. If $C \rightarrow \infty$, all the RUs have perfect fronthaul link to the CU and hence can be considered as a single base station with N receive antennas. Hence, there is no need to perform in-network processing at the RUs, and we can set $\gamma = 0$ without loss of optimality. The achievable rate is given as

$$R_\Sigma = \frac{1}{2} \sum_{i \in \mathcal{N}} \log_2 \left(1 + P \frac{1 + \alpha^2 + 2\alpha \cos(2\pi \frac{i-1}{N})}{\sigma^2} \right), \quad (16)$$

since $\beta_C \rightarrow 0$ as $C \rightarrow \infty$. We remark that the above rate expression divided by the number N of cells converges to the rate derived in [10, Eq. (3.15)] as $N \rightarrow \infty$.

V. LEVERAGING SIDE INFORMATION

In this section, we discuss the maximization of the achievable sum-rate under the assumption that the RUs and CU decompress the received quantized signals utilizing available SI.

If we assume that the RU $[i+1]$ decompresses the signal $\hat{Y}_{B,i}$ using the uplink received signal $Y_{[i+1]}$ as SI, the condition (8) on the quantization noise power ω_B can be relaxed as [12, Ch. 12]

$$\begin{aligned} g_B(\omega_{B,i}) &\triangleq I(Y_i; \hat{Y}_{B,i} | Y_{[i+1]}) \\ &= \frac{1}{2} \log_2 \left(1 + \frac{E[Y_i^2 | Y_{[i+1]}]}{\omega_B} \right) \leq B, \end{aligned} \quad (17)$$

where the conditional power $E[Y_i^2 | Y_{[i+1]}]$ is given as

$$E[Y_i^2 | Y_{[i+1]}] = (1 + \alpha^2)P + \sigma^2 - \frac{\alpha^2 P^2}{(1 + \alpha^2)P + \sigma^2}. \quad (18)$$

In order to fully use the capacity of the inter-RU fronthaul links, we fix the quantization noise powers ω_B for the inter-RU links such that the conditions (17) are satisfied with equality as

$$\omega_B = \beta_B E[Y_i^2 | Y_{[i+1]}], \quad (19)$$

for all $i \in \mathcal{N}$.

As in [6], the CU decompresses the signals $\hat{Y}_{C,1}, \dots, \hat{Y}_{C,N}$ received from the RUs on the fronthaul links in a successive manner with the order $\hat{Y}_{C,1} \rightarrow \hat{Y}_{C,2} \rightarrow \dots \rightarrow \hat{Y}_{C,N}$. This means that the signal $\hat{Y}_{C,1}$ sent by the first RU is decompressed without SI, while the other signals $\{\hat{Y}_{C,i}\}_{i=2}^N$ are decompressed by using the previously recovered signals.

In order to simplify the analysis, we assume that the CU decompresses each signal $\hat{Y}_{C,i}$, $i > 1$, by utilizing only the signal $\hat{Y}_{C,i-1}$ as SI. This choice is justified since this is the most correlated to $\hat{Y}_{C,i}$ among the previously recovered signals $\hat{Y}_{C,1}, \dots, \hat{Y}_{C,i-1}$ due to the partial connectivity of the Wyner model. As a result, we set the quantization noise power $\omega_{C,1}$ to (13) since the CU cannot leverage SI while decompressing the signal $\hat{Y}_{C,1}$. The condition on the other quantization noise powers $\omega_{C,i}$, $i > 1$, and the in-network processing coefficients γ is instead stated as

$$I(S_i; \hat{Y}_{C,i} | \hat{Y}_{C,i-1}) = \frac{1}{2} \log_2 \left(1 + \frac{E[S_i^2 | \hat{Y}_{C,i-1}]}{\omega_{C,i}} \right) \leq C, \quad (20)$$

where the conditional variances $E[S_i^2 | \hat{Y}_{C,i-1}]$ are given as

$$E[S_i^2 | \hat{Y}_{C,i-1}] = E[S_i^2] - \frac{E[S_i \hat{Y}_{C,i-1}]^2}{E[\hat{Y}_{C,i-1}^2]}, \quad (21)$$

with

$$E[S_i \hat{Y}_{C,i-1}]^2 = (\gamma + \alpha)P + \gamma\alpha(\gamma + \alpha)P + \gamma\sigma^2, \quad (22)$$

$$E[\hat{Y}_{C,i-1}^2] = \left(\gamma^2\alpha^2 + (\gamma + \alpha)^2 + 1 \right) P + (1 + \gamma^2)\sigma^2 + \gamma^2\omega_B + \omega_{C,i-1}. \quad (23)$$

For given combiner γ , similar to (19) for the inter-RU fronthaul links, we set the quantization noise powers $\omega_{C,i}$, $i > 1$, to the minimum value that satisfies the condition (20) as

$$\omega_{C,i} = \beta_C E[S_i^2 | \hat{Y}_{C,i-1}]. \quad (24)$$

The main result for SI compression is summarized in the following proposition.

Proposition 2. *An achievable sum-rate R_Σ with SI compression is given by the solution of the problem*

$$\underset{\gamma}{\text{maximize}} \quad \tilde{f}_{\text{SI}}(\gamma), \quad (25)$$

where the function $\tilde{f}_{\text{SI}}(\gamma)$ is defined in (6) with ω_B , $\omega_{C,1}$ and $\omega_{C,i}$, $i > 1$, given as (19), (13) and (24), respectively.

Similar to (14), the optimal combining coefficient γ in (25) can be found via a one-dimensional search.

VI. JOINT DECOMPRESSION AND DECODING

In this section, we finally discuss the achievable sum-rate under the assumption that the CU performs jointly the decompression and decoding tasks.

For given ω_B , ω_C and γ , the achievable sum-rate under joint decompression and decoding (JDD) was derived in [2] and [13] as

$$R_\Sigma = \min_{S \subseteq \mathcal{N}} \left\{ |\mathcal{S}|C - \sum_{i \in \mathcal{S}} I(S_i; \hat{Y}_{C,i} | \mathbf{X}) + I(\mathbf{X}; \{\hat{Y}_{C,i}\}_{i \in \mathcal{S}^c}) \right\} \quad (26)$$

$$= \min_{S \subseteq \mathcal{N}} \{ |\mathcal{S}|(C - \tilde{g}_C(\omega_B, \omega_C, \gamma)) + f_{C,S}(\omega_C, \omega_B, \gamma) \},$$

where we defined the notation $\mathcal{S}^c \triangleq \mathcal{N} \setminus \mathcal{S}$ and the functions $f_{C,S}(\omega_C, \omega_B, \gamma)$ and $\tilde{g}_C(\omega_B, \omega_C, \gamma)$ as

$$f_{C,S}(\omega_C, \omega_B, \gamma) \triangleq I(\mathbf{X}; \{\hat{Y}_{C,i}\}_{i \in \mathcal{N} \setminus \mathcal{S}}) \quad (27)$$

$$= \frac{1}{2} \log_2 \left| \left(\begin{array}{c} \mathbf{I} + \mathbf{P}\mathbf{H}_{X,S}\mathbf{H}_{X,S}^T \\ \sigma^2\mathbf{H}_{Z,S}\mathbf{H}_{Z,S}^T + \\ \omega_B\mathbf{H}_{Q,S}\mathbf{H}_{Q,S}^T + \omega_C\mathbf{I} \end{array} \right)^{-1} \right|,$$

$$\tilde{g}_C(\omega_B, \omega_C, \gamma) \triangleq I(S_i; \hat{Y}_{C,i} | \mathbf{X}) \quad (28)$$

$$= \frac{1}{2} \log_2 \left(1 + \frac{\gamma^2\omega_B + (1 + \gamma^2)\sigma^2}{\omega_C} \right).$$

Here the matrices $\mathbf{H}_{Z,S}$, $\mathbf{H}_{Q,S}$ and $\mathbf{H}_{X,S}$ are obtained by removing the rows indexed by the elements of \mathcal{S} from the matrices \mathbf{H}_Z , \mathbf{H}_Q and \mathbf{H}_X , respectively, in (5). Also, we recall that S_i denotes the combining output signal (4) at RU i .

We now aim at finding the variables ω_B , ω_C and γ that maximize the sum-rate (26) achievable with JDD. Without claim of optimality, we first fix the quantization noise power ω_B for the inter-RU links according to (12) or (19) for the P2P or SI compression strategies, respectively, since they are the minimum values of ω_B that satisfy the conditions (8) and (17). We then observe that for given γ , finding ω_C that maximizes the sum-rate (26) is a difference-of-convex (DC) problem. Therefore, we can derive an algorithm whereby we perform a search over the variables γ in the outer loop while the inner loop finds a suboptimal solution of ω_C for given γ by means of the concave convex procedure (CCCP) approach. Details are omitted due to space limitations.

VII. NUMERICAL EXAMPLES

In this section, we present some numerical examples that compare the following performance curves.

- *Cut-set upper bound:* The cut-set upper bound R_{UB} given as [10]

$$R_{\text{UB}} = \min \{ R_{\text{full}}, NC \}, \quad (29)$$

where R_{full} is the sum-rate (16) that can be achieved when the RUs can cooperate with perfect fronthaul link (i.e., $C \rightarrow \infty$).

- *Oblivious upper bound:* We also consider an upper bound that accounts for the performance limitations due to oblivious processing at the RUs. This is obtained by assuming that the RUs are collocated and send a jointly quantized signals of the uplink received signals $\{Y_i\}_{i \in \mathcal{N}}$ to the CU on the fronthaul link of capacity NC . In this case, the RUs can be regarded as a single RU with N receive antennas and the optimal covariance matrix of the quantization noise vector can be obtained by using the result in [3, Thm. 1].

- *P2P/SI compression w/o inter-RU links:* Sum-rate that can be achieved with the P2P or SI compression schemes with no use of the inter-RU links, i.e., $B = 0$.

- *P2P/SI compression with inter-RU links:* Sum-rate that can be achieved with the P2P or SI compression schemes with the optimal combining coefficients γ as discussed in Sec. IV and Sec. V.

- *Joint decompression and decoding:* Sum-rate that can be achieved with the JDD discussed in Sec. VI.

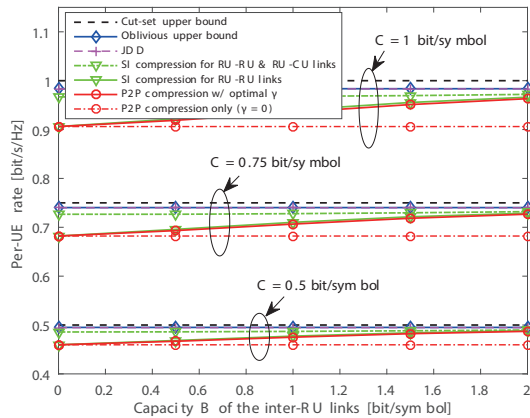

Figure 3. Per-UE rate versus the capacity B of the inter-RU links with $N = 3$, $\alpha = 0.7$, $P/\sigma^2 = 20$ dB and $C = \{0.5, 0.75, 1\}$ bit/symbol.

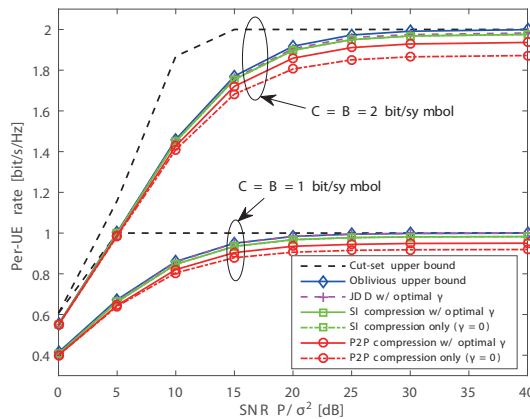

Figure 4. Per-UE rate versus the SNR P/σ^2 with $N = 3$, $\alpha = 0.7$ and $C = B \in \{1, 2\}$ bit/symbol.

In Fig. 3, we investigate the advantages of inter-RU cooperation by plotting the per-UE rate, which is given as the sum-rate divided by the number N of UEs, versus the inter-RU capacity B for a Wyner-type uplink C-RAN with $N = 3$, $\alpha = 0.7$, $P/\sigma^2 = 20$ dB and $C = \{0.5, 0.75, 1\}$ bit/symbol. It is observed that, with in-network processing, the performance approaches the oblivious upper bound as the inter-RU capacity B increases. Also, we can see that, especially for small B , leveraging SI for the RU-to-CU links leads to a more significant sum-rate gain as compared to leveraging SI for the inter-RU links. Moreover, JDD further improves the sum-rate performance.

Fig. 4 shows the per-UE rate with respect to the SNR P/σ^2 for the Wyner model with $N = 3$, $\alpha = 0.7$ and $C = B \in \{1, 2\}$ bit/symbol. It is seen that, for P2P compression, the advantage of utilizing the inter-RU link is more evident at a higher SNR, since, in this regime, the fronthaul link to the CU becomes the performance bottleneck. Also, JDD shows slightly improved sum-rate performance, but the gap to the cut-set bound is still large in the low-to-intermediate SNR regime.

By comparison with the oblivious upper bound, this gap can be bridged only via the development of achievable scheme based on non-oblivious RU processing. Furthermore, the impact of using inter-RU links is more clear for P2P compression than for the SI compression scheme, given that the latter makes a more efficient use of the RU-to-CU fronthaul links.

VIII. CONCLUDING REMARKS

In this paper, we have studied the role of inter-RU fronthaul links as a means for improving the uplink sum-rate of C-RAN systems under the assumptions of oblivious in-network processing at RUs and of a linear Wyner-type topology. We derived analytical expressions of the achievable sum-rates with P2P compression and compression schemes that leverage SI. Via numerical examples, we observed that the performance with in-network processing approaches the oblivious upper bound as the inter-RU capacity increases and that leveraging SI for the RU-to-CU links is more advantageous than leveraging SI for the inter-RU links. Among topics for future work, we mention the development of improved lower and upper bounds and the extension of the analysis to C-RAN uplink set-ups with fading channels.

REFERENCES

- [1] O. Simeone, A. Maeder, M. Peng, O. Sahin and W. Yu, "Cloud radio access network: Virtualizing wireless access for dense heterogeneous systems," *Journ. Commun. Networks*, vol. 18, no. 2, pp. 135-149, Apr. 2016.
- [2] A. Sanderovich, O. Somekh, H. V. Poor and S. Shamai (Shitz), "Uplink macro diversity with limited backhaul cellular networks," *IEEE Trans. Inf. Theory*, vol. 55, no. 8, pp. 3457-3478, Aug. 2009.
- [3] A. d. Coso and S. Simoens, "Distributed compression for MIMO coordinated networks with a backhaul constraint," *IEEE Trans. Wireless Comm.*, vol. 8, no. 9, pp. 4698-4709, Sep. 2009.
- [4] S.-H. Park, O. Simeone, O. Sahin and S. Shamai (Shitz), "Joint decomposition and decoding for cloud radio access networks," *IEEE Sig. Processing Letters*, vol. 20, no. 5, pp. 503-506, May 2013.
- [5] L. Zhou and W. Yu, "Uplink multicell processing with limited backhaul via per-base-station successive interference cancellation," *IEEE Journ. Sel. Areas Commun.*, vol. 31, no. 10, pp. 1981-1993, Oct. 2013.
- [6] S.-H. Park, O. Simeone, O. Sahin and S. Shamai (Shitz), "Fronthaul compression for cloud radio access networks: Signal processing advances inspired by network information theory," *IEEE Sig. Processing Mag.*, vol. 31, no. 6, pp. 69-79, Nov. 2014.
- [7] Y. Zhou, Y. Xu, W. Yu and J. Chen, "On the optimal fronthaul compression and decoding strategies for uplink cloud radio access networks," *IEEE Trans. Inf. Theory*, vol. 62, no. 12, pp. 7402-7418, Dec. 2016.
- [8] M. Shafi and et al., "5G: A tutorial overview of standards, trials, challenges, deployments and practice," *IEEE Journ. Sel. Areas Commun.*, vol. 35, no. 6, pp. 1201-1221, Jun. 2017.
- [9] O. Simeone, O. Somekh, H. V. Poor and S. Shamai (Shitz), "Local base station cooperation via finite-capacity links for the uplink of linear cellular networks," *IEEE Trans. Inf. Theory*, vol. 55, no. 1, pp. 190-204, Jan. 2009.
- [10] O. Simeone, N. Levy, A. Sanderovich, O. Somekh, B. M. Zaidel, H. V. Poor and S. Shamai (Shitz), "Cooperative wireless cellular systems: An information-theoretic view," *Foundations and Trends in Commun. Inf. Theory*, vol. 8, nos. 1-2, 2011, pp. 1-177, Now Publishers, 2012.
- [11] M. Wigger, R. Timo and S. Shamai (Shitz), "Conferencing in Wyner's asymmetric interference networks: Effect of number of rounds," *IEEE Trans. Inf. Theory*, vol. 63, no. 2, pp. 1199-1226, Feb. 2017.
- [12] A. E. Gamal and Y.-H. Kim, *Network information theory*, Cambridge University Press, 2011.
- [13] S. H. Lim, Y.-H. Kim, A. E. Gamal and S.-Y. Chung, "Noisy network coding," *IEEE Trans. Inf. Theory*, vol. 57, no. 5, pp. 3132-3152, May 2011.